



PAPER • OPEN ACCESS

## Gas Source Localization via Behaviour Based Mobile Robot and Weighted Arithmetic Mean

To cite this article: Ahmad Shakaff Ali Yeon *et al* 2018 *IOP Conf. Ser.: Mater. Sci. Eng.* **318** 012049

View the [article online](#) for updates and enhancements.

You may also like

- [Using Air Curtains in Gas Sensing System to Enhance Its Directivity](#)  
Takafumi Kusunoki and Hiroshi Ishida
- [A novel traveling wave piezoelectric actuated tracked mobile robot utilizing friction effect](#)  
Liang Wang, Chengyou Shu, Jiamei Jin *et al.*
- [Research on mobile robot path planning in complex environment based on DRQN algorithm](#)  
Shuai Wang, Yuhong Du, Jingxuan Lin *et al.*

**ECS** The Electrochemical Society  
Advancing solid state & electrochemical science & technology

**247th ECS Meeting**  
Montréal, Canada  
May 18-22, 2025  
*Palais des Congrès de Montréal*

**Abstracts due December 6th**

**Showcase your science!**

# Gas Source Localization via Behaviour Based Mobile Robot and Weighted Arithmetic Mean

Ahmad Shakaff Ali Yeon<sup>1</sup>, Kamarulzaman Kamarudin<sup>1,2</sup>, Retnam Visvanathan<sup>1</sup>, Syed Muhammad Mamduh Syed Zakaria<sup>1</sup>, Ammar Zakaria<sup>1,2</sup>, Latifah Munirah Kamarudin<sup>1</sup>

<sup>1</sup>CEASTech, Universiti Malaysia Perlis (UniMAP), Malaysia

<sup>2</sup>School of Mechatronic, Universiti Malaysia Perlis (UniMAP), Malaysia

E-mail: kamarulzaman@unimap.edu.my

**Abstract.** This work is concerned with the localization of gas source in dynamic indoor environment using a single mobile robot system. Algorithms such as Braitenberg, Zig-Zag and the combination of the two were implemented on the mobile robot as gas plume searching and tracing behaviours. To calculate the gas source location, a weighted arithmetic mean strategy was used. All experiments were done on an experimental testbed consisting of a large gas sensor array (LGSA) to monitor real-time gas concentration within the testbed. Ethanol gas was released within the testbed and the source location was marked using a pattern that can be tracked by a pattern tracking system. A pattern template was also mounted on the mobile robot to track the trajectory of the mobile robot. Measurements taken by the mobile robot and the LGSA were then compared to verify the experiments. A combined total of 36.5 hours of real time experimental runs were done and the typical results from such experiments were presented in this paper. From the results, we obtained gas source localization errors between 0.4m to 1.2m from the real source location.

## 1. Introduction

Work on mobile olfaction began by mimicking the behaviour of organisms based on the studies of chemotaxis on bacteria being attracted and repelled by chemicals. Combining our understanding of chemotaxis with the recent advancements in mobile robotics, the world now have a mature and popular research field which consists of using mobile robots and gas sensors to find, trace and localize chemical gas plumes. While the early works on mobile olfaction only began in the early 1990s, it was believed that Larcombe and Halsall [1] was the first time where chemically sensitive robot devices were seriously being discussed to be deployed in the hazardous nuclear industry's environment. In general, mobile olfaction can be divided into three equally important sub problems that need to be solved which are gas plume searching, gas plume tracing and gas source declaration.

### 1.1. Gas Plume Searching

Commonly used technique or algorithm for gas plume searching is by searching upwind [2-5] because gasses will always travel in the air along with the wind in the same direction. The mobile robot might still miss the gas plume as it travels upwind if the implemented searching technique is not able to cover a large dynamic environment. There are also other factors that are detrimental to the success of solving this step such as gas sensor position, gas sensor sensitivity, gas sensor response time and others.



In an indoor environment or where the physical state of the space is known, wind information is less likely needed. A carefully planned searching algorithm can manage to traverse through the whole area without problems [6] but the time to cover the whole area might differ based on the mobile robot's speed and the size of the area.

### *1.2. Gas Plume Tracing*

After finding the gas plume, the mobile robot will need to solve the second problem of mobile olfaction which is gas plume tracing or in other words, move reactively along or within the gas plume. The most common technique in plume tracing is by taking measurements of the gas concentration at different points and calculates its differences to gain information about the gas plume gradient which then can be exploited to navigate the mobile robot to the gas source.

### *1.3. Gas Source Declaration*

The definition of gas source declaration varies from research group to research group. Gas source declaration is the process of determining the certainty that the gas source is in the immediate vicinity thus ending the robot's run [7].

Up till now, there are only a few techniques to solve the gas source declaration problem and most of them involved the authors of past works to declare an area surrounding the known gas source location as the goal which means that if the mobile robot enters the area, it is count as a successful experimental run. Other techniques are machine learning, neural network algorithms and gas distribution mapping.

### *1.4. Problem Statement*

Earlier works focused on making the mobile robots to arrive within a certain radius from the actual gas source location. This method while valid is biased with the assumption that the mobile robot knows that it has arrived near the actual gas source. Furthermore, artificial neural network (ANN) [7, 27-28] was utilized to make the mobile robot recognize that it has found the actual gas source but this technique requires extensive development time for training.

Recent advancements in solving the gas source localization problem are more concentrated in developing gas distribution map building techniques [32-34]. In general, the mobile robot will construct a map of the environment and overlaying it with gas distribution map. The downside of gas distribution mapping is that the approach is complex and requires high computing power for analysis and computation [35]. Researchers often neglect autonomous path planning of the mobile robot as a compromise.

Finally, there is no standard external system or method to verify the gas sensor measurements from the mobile robot. Researchers have been using cameras to verify mobile robot's trajectory, pose, and odometry but very few have tried to verify the gas sensor measurements taken by the mobile robot.

In this work, a large gas sensor array was utilized to verify the gas sensor measurements taken by the mobile robot. This was done by comparing the mobile robot's measurement with the measurement take by the sensor arrays [30]. A combination of low level algorithms was also implemented on the mobile robot to navigate the mobile robot autonomously while the mobile robot transmits its data to a central workstation for calculating the gas source location. These steps were taken to keep the mobile robot a low monetary and low computation cost and its data verifiable while also able to perform gas source localization tasks autonomously.

## **2. Related Works**

### *2.1. Chemotaxis*

Chemotaxis is a strategy used by researchers to solve the gas source localization problem by exploiting gas concentration measurements from gas sensors.

Rozas algorithm [9] has been the kickstarter for chemotaxis. It emphasized on gradient following strategy by taking multiple spatial measurements at different times. After taking the gas sensor

measurements, the robot will turn to the direction of the sensor with highest gradient of chemical concentration then move forward into the direction for  $m$  meters.

Pre-programmed moveset like the Rozas were implemented in a few other works. Kuwana [10] worked on mimicking the Silkworm Moth behaviour to move the robot towards a gas source. Pheromone sensors were used and have been found to be fast degrading compared to chemical sensors. The work was improved at the cost of sensor's longevity [11]. The mobile robot was successful in mimicking the Silkworm Moth's zig-zag movements towards the gas source. Kazadi [12] improved the works of Kuwana with polymer sensors which are sensitive to wind. By using polymer sensors, the mobile robot managed to turn faster towards the gas source.

Furthermore, a popular method of navigation strategy which is the Braitenberg strategy. A pure Braitenberg vehicle has two sensors sufficiently separated and placed opposite of each other with each of them controlling the wheel on the same side or cross-coupling to control the wheel on the opposite side [13]. Sandini [14] executed the strategy with his mobile robot. From the work, the mobile robot showed reactive potential towards gas concentration. The Braitenberg has been studied quite thoroughly. A reactive Braitenberg or in other words, continuous sampling of gas concentration has been studied and was found to be far more successful [15]. Two Braitenberg strategies (Attract and Repel) were also studied and comparison work has been done [16]. Repel strategy often avoid the gas source and the avoided areas can be deemed as the gas source location.

Moreover, other biologically inspired algorithms have been utilized in mobile olfaction. A popular one is the biased random walk of *E.coli* [17-19]. Cleverly planned navigation strategy such as Sweeping [6], Hex-path [18], Spiral [19] and Surge [20] were also implemented in past works which can be utilized to solve the navigation part of gas source localization problem.

## 2.2. Gas Source Declaration

The common technique used to declare a gas source is by manually declaring an area surrounding the actual gas source location as the gas source. When a part of the mobile robot reaches said area, it usually counted as a 'hit' and the experiment deemed successful [11,19,21-23].

Buscemi [24] developed a heuristic approach based on gas sensor saturation for gas source declaration. Then, Grasso and Atema [25] tried a similar approach with the addition of a threshold over a sampling period. Due to the volatile nature of the gasses, Cowen [26] proposed another heuristic method comparing concentration measurements at different heights to help solving the gas source declaration in a case of gasses that are lighter than air and was verified [5]. In addition to heuristics, machine learning, support vector machine and neural network approaches were also taken by researchers to tackle this problem [7, 27-28]. Although these works showed positive results in declaring the gas source location, neural network algorithms and machine learning requires extensive training period.

Particle filter based odour source declaration algorithm was also implemented using mobile robot [20]. The usage of the particle filter algorithm was extended to gas source declaration using multiple static gas sensor nodes via wireless sensor network [29].

Gas distribution mapping technique by combining gas sensor data with location estimations can also be classified as a gas source declaration technique by some research groups where the declaration is performed by the researcher by interpreting the map generated by the robots [8].

## 3. System Overview

Figure 1 shows the overall architecture of the system for solving gas source localization problem. Within the system, there are three smaller subsystems namely the integrated mobile robot, large gas sensor array (LGSA) for data verification [30], and the robot tracking system [31] working simultaneously to gather data and transmit the data through WSN and intranet to a remotely located base station PC for processing.

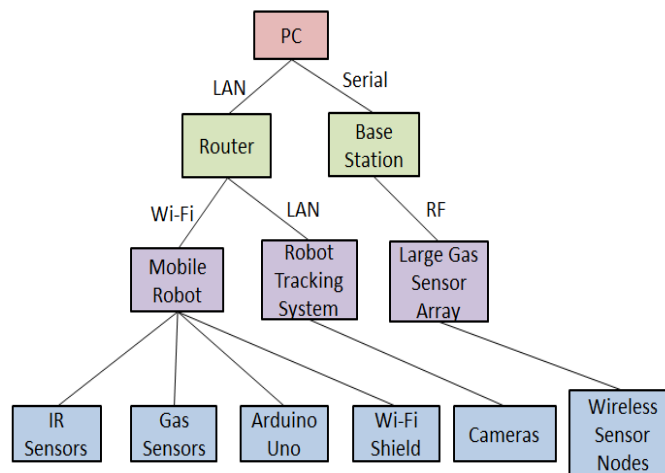

**Figure 1.** System block diagram of the integrated system.

### 3.1. Mobile Robot

Arduino Mobile Robot was chosen to be the mobile robot platform for this work. The Arduino robot is a very low-cost consumer grade hobby kit which is suitable for educational purposes. It consist two processors and two microcontrollers with one each on its motor board and control board. It is easily programmable and highly modifiable but limited amount of digital and analog I/O pins available on the two boards. The robot was modified to meet our standards to perform gas source localization task and programmed to move its wheels based on certain conditions which will be explained further in Section 4. Figure 2 shows the mobile robot system used throughout this work.

Wi-Fi shield is needed to establish communication with the base station wirelessly. An additional microcontroller which is the Arduino Uno is mounted and connected to the mobile robot to accommodate a Wi-Fi shield. The data collected are raw voltages of the gas sensors in form of 10-bit data. Conversion of the raw voltage values from digital,  $V_d$  to analog raw voltage values,  $V_a$  is shown in Equation (1) where  $V_{ref}$  is the reference voltage of the board. For Arduino Uno and Arduino robot,  $V_{ref}$  is 5V. The analog digital converter of the Arduino Uno is similar to the analog digital converter of the Arduino Robot.

$$V_a = (V_d / 1024) \times V_{ref} \quad (1)$$

### 3.2. Gas Sensor

Two Figaro TGS 2600 MOX gas sensor were mounted on the robot with one on each side with a 18cm of separation between each other. Two electrical circuit boards consisting of a single 10k $\Omega$  resistor,  $R_L$  each were made to mount the sensors and connect it to the robot's and the Arduino UNO's digital I/O channels. 10-bit data of raw voltages,  $V_d$  were obtained and converted into analog values,  $V_a$  as shown in Equation (1). From the analog raw voltage, the resistance of the gas sensor,  $R_s$  can be calculated as shown in Equation (2).

$$R_s = [(V_{ref} \times R_L) / V_a] - R_L \quad (2)$$

From Equation (2), sensor signal value  $s$  can be obtained as shown in Equation (3)

$$s = \Delta R / R_0 = [(R_0 - R_s) / R_0] = 1 - (R_s / R_0) \quad (3)$$

where  $R_0$  is the baseline resistance taken at the start of an experiment. The sensor reading before gas is released is taken to be the baseline reading,  $R_0$ . The sensor signal values were used throughout this work mainly to control the mobile robot's motor in the Braitenberg algorithm and for the generation of gas distribution map of the testbed for verification.

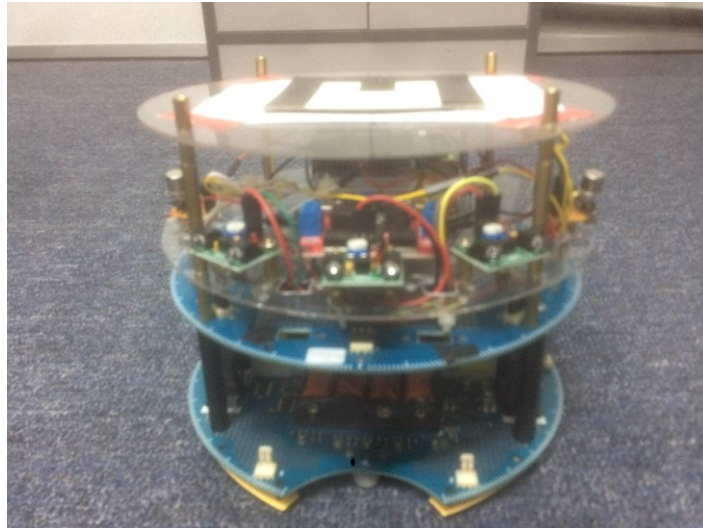

**Figure 2.** The modified Arduino Mobile Robot platform with a pattern template on top for robot tracking purposes.

## 4. Algorithms

### 4.1. Zig-Zag

In this work, the the traditional Zig-Zag was modified and will primarily act as the searching technique to cover the area within the testbed with the aid of on board compass and IR sensors. The mobile robot will perform the programmed evasive manoeuvre when the IR sensors detect an obstacle which in this case is the testbed's wall.

---

```

Zig-Zag Algorithm
Initialize parameters
Wait 90 seconds
while(robot power on)
    record sensors measurement
    set direction
    read compass value
    if(obstacles detected)
        evasive maneuver
    else if(compass value > direction)
        set speedLeft > speedRight
    else if(compass value < direction)
        set speedLeft < speedRight
    else if(compass value =direction)
        set speedLeft = speedRight
    end
end

```

---

**Figure 3.** Pseudocode of the Zig-Zag algorithm.

#### 4.2. Braitenberg

Variety of Braitenberg strategy has been used by past works to perform olfaction research with mobile robots. In this work, the ‘attract’ and ‘repel’ behaviour were implemented. During the ‘attract’ behaviour, the motor will turn to the side of the higher gas sensor measurement while the opposite happen during the ‘repel’ behaviour.

---

```

Braitenberg Algorithm
Initialize parameters
wait 90 seconds
record initial sensor measurement
calculate initial sensor resistance,  $R_{ol}, R_{or}$ 
while(robot power on)
    record sensors measurement
    calculate current sensor resistance,  $R_{sl}, R_{sr}$ 
    calculate sensor signal,  $s_l, s_r$ 
    if(obstacles detected)
        evasive maneuver
    else
        calculate speedRight
        calculate speedLeft
        set speedRight and speedLeft
    end
end

```

---

**Figure 4.** Pseudocode of the Braitenberg algorithm.

#### 4.3. B+Z

Both the Braitenberg and Zig-Zag algorithm were then combined into one to form a multi-phase algorithm which consists of a searching phase utilizing the Zig-Zag algorithm and a tracing phase using the Braitenberg algorithm.

The algorithm works with by executing one of the two algorithms within certain conditions. The mobile robot will always calculate the values of sensor signals  $s_l$  and  $s_r$  while always searching for obstacles with its IR sensors.

#### 4.4. Gas Source Declaration Strategy

For gas source declaration (GSD), we would like to distance ourselves from the traditional way of declaring an experimental run as successful or a failure depending on the ability of the mobile robot to get into the near vicinity of the known actual gas source location or also known as ‘hits’. Strategies such as machine learning and neural network were utilized in past works but it proved to be too costly in terms of memory and computing power to be implemented on our Arduino robot system.

In this work, weighted arithmetic mean is proposed. The centroid of the gas plume position were calculated by exploiting the information gained throughout the experimental run such as the sensor voltages and sensor signal values by applying them to act as weights to the robot’s position.

The simplified mathematical definition can be explained as follows. A non-empty set of data consists of x-axis and y-axis coordinates denoted as  $\{x_1, x_2, x_3, \dots, x_n\}$  and  $\{y_1, y_2, y_3, \dots, y_n\}$ . A set of sensor measurements taken at the particular coordinate such as sensor voltages or signal values act as weights can be denoted as  $\{w_1, w_2, w_3, \dots, w_n\}$ . Equation (4) and (5) denotes the calculation of the weighted mean where  $x_p$  and  $y_p$  is the predicted x-axis and y-axis position of the gas source.

$$x_p = (x_1 w_1 + x_2 w_2 + \dots) / (w_1 + w_2 + \dots) \quad (4)$$

$$y_p = (y_1 w_1 + y_2 w_2 + \dots) / (w_1 + w_2 + \dots) \quad (5)$$

In this work, the variables used as weight are the raw gas sensors voltages and sensor signals. All the variations are as follows:

1. Type A: GSD using raw voltage measurement.
2. Type B: GSD using all sensor signal values.
3. Type C: GSD using all positive sensor signal values.
4. Type D: GSD using all sensor signal values over 0.3

Note that the GSD performed is not in real-time. The predicted gas source location was calculated immediately after the experimental run was completed using MATLAB on the base station PC as all recorded data from the LGSA, mobile robot tracking system and the gas sensor measurements from the mobile robot were sent to and stored in the base station PC.

---

**B+Z Algorithm**

---

```

Initialize parameters
wait 90 seconds
record initial sensor measurement
calculate initial sensor resistance,  $R_{0l}$ ,  $R_{0r}$ 
while(robot power on)
    record sensors measurement
    read compass value
    calculate current sensor resistance,  $R_{sl}$ ,  $R_{sr}$ 
    calculate sensor signal,  $s_l$ ,  $s_r$ 
    if(obstacles detected)
        evasive maneuver
    else if( $R_{sl}/R_{0l} \leq 0.3$  and  $R_{sr}/R_{0r} \leq 0.3$ )
        set direction
        if(compass value > direction)
            set speedLeft > speedRight
        else if(compass value < direction)
            set speedLeft < speedRight
        else if(compass value = direction)
            set speedLeft = speedRight
        end
    else if( $R_{sl}/R_{0l} > 0.3$  or  $R_{sr}/R_{0r} > 0.3$ )
        calculate speedRight
        calculate speedLeft
        set speedRight and speedLeft
    end
end

```

---

**Figure 5.** Pseudocode of the B+Z algorithm.

## 5. Experimental Setup

The setups for the experiments are as follows:

- 1) Robot starting position at  $(x,y) = (30,550)$ .
- 2) Ethanol gas released position at  $(x,y) = (150,220)$ , at the height of 20cm from the ground and at actual robot start time.
- 3) Number of runs for each algorithm:
  - a. Zig-Zag: 5 runs.
  - b. Braitenberg (Attract & Repel): 10 runs.
  - c. B+Z (Attract & Repel): 20 runs.
- 5) Stop conditions:
  - a. 10 minutes of run time.



- b. Mobile robot reached the other end of the testbed after completing either searching or tracing phase.

Before the mobile robot perform its task, it will first sit through a wait time period of 90 seconds where the robot is turned on but not doing anything of significance. This is so that the gas sensors on board the mobile robot have enough time to heat up and normalize its measurements.

## 6. Experiments & Results

The results for GSD errors for all types are presented in Table 1. Examples of the robot's trajectory when implementing the Zig-Zag, Braitenberg and B+Z algorithms are illustrated in Figure 6 to Figure 8.

**Table 1.** Average GSD Error for all types of algorithm.

Algorithm	Average GSD Error ( $m$ )			
	A	B	C	D
Zig-Zag	0.68	0.78	0.75	1.05
Braitenberg (Attract)	0.74	0.57	0.39	0.79
Braitenberg (Repel)	0.63	0.62	0.62	0.72
B+Z (Attract)	0.82	1.22	0.65	0.68
B+Z (Repel)	0.82	0.91	0.51	0.66

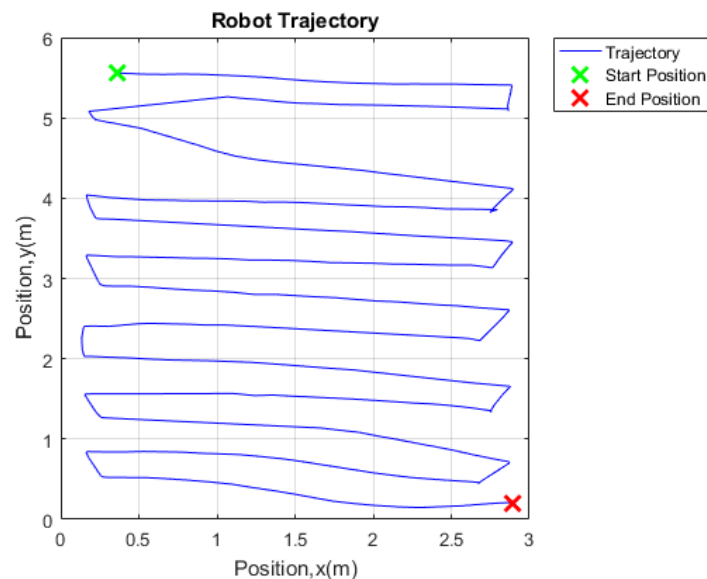
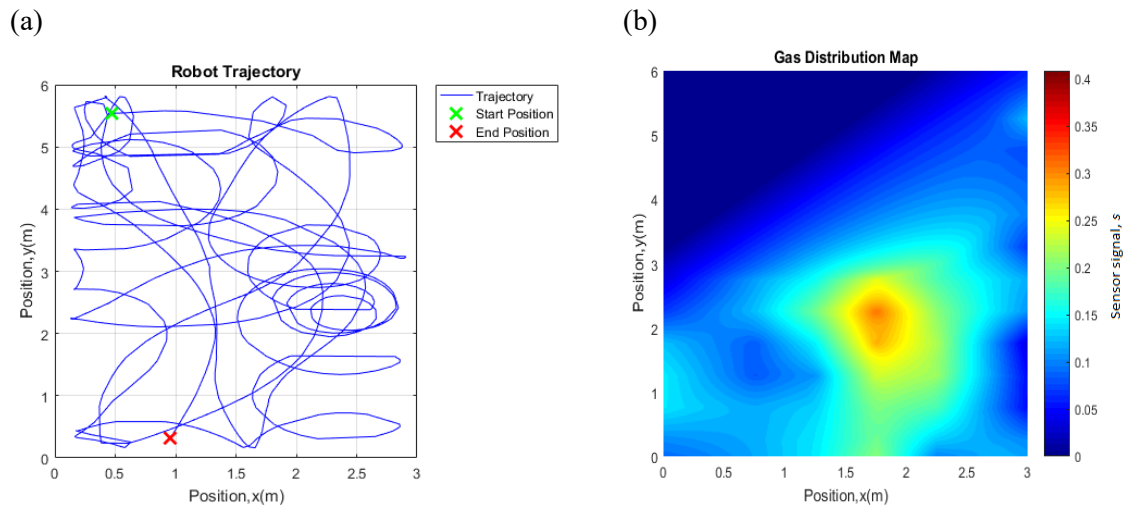

**Figure 6.** The mobile robot's trajectories after implementing the Zig-Zag algorithm Run #3.

From Table 1, it was found that localization errors by calculating the source location using the sensor's raw voltage data (Type A) are very reasonable ranging from 0.63m to 0.82m. The errors are worse when calculating the source location by using raw sensor signal values (Type B). It is believed that the baseline sensor resistance value  $R_0$  taken at the beginning of every run to calculate the sensor signal values is the main reason for the worse results as it regularly dropped to negative values of  $s$ . Apart from circuitry noises skewing the values, a longer wait time for the sensor to normalize is needed. By removing only the negative values (Type C), the errors were reduced greatly.

Moreover, from the results, it can be seen that by calculating the gas source location by only using  $s \geq 0.3$  (Type D), or in other words, taking only the higher end of the measurements, the calculated source location got worse. This confirms the idea that the areas of high gas concentration

values are not always at the source or near its vicinity [16] due to the turbulent nature of the gasses in the environment.



**Figure 7.** The figure (a) illustrates the robot's trajectory implementing the Braitenberg Attract algorithm Run #6 while figure (b) is the average gas concentration map for the run.

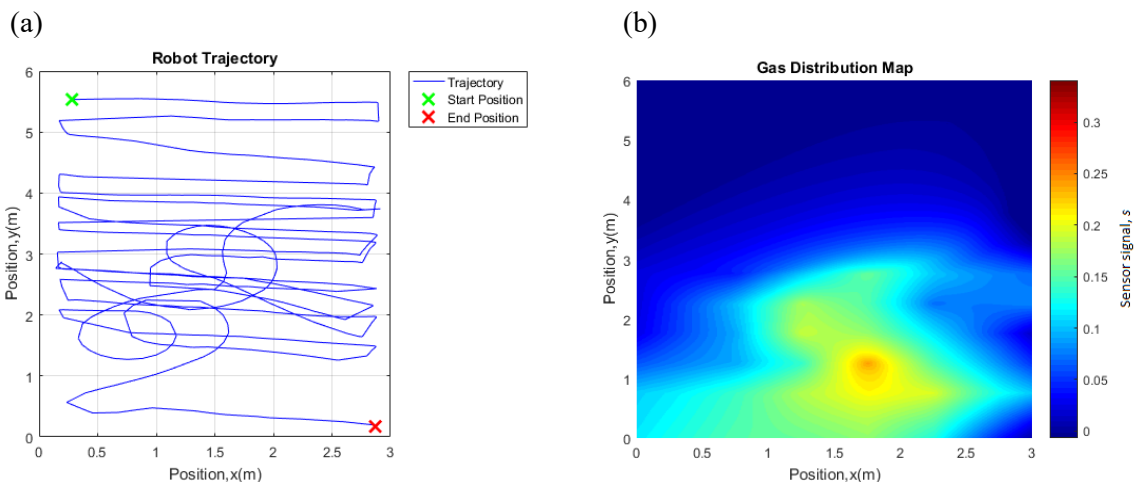

**Figure 8.** This is the experimental Run #7 of the B+Z attract algorithm. The mobile robot's trajectory (a) after completing a B+Z (Attract) algorithm clearly depicts the combination of the Zig-Zag and the Braitenberg. While (b) shows the average gas concentration map for B+Z (Attract) Run #7.

## 7. Conclusion & Future Work

A weighted arithmetic mean to calculate and predict the gas source location was successfully implemented. From the results, it was found that even with the rigid Zig-Zag moveset, a reasonable average error of 0.68m from the actual gas source location can be achieved. The error can be further lowered by the Braitenberg and the B+Z due to its tracing capability. The lowest average error (0.39m) achieved in this research is by the Braitenberg (Attract) but at the cost of a longer run time due to continuous roaming of the mobile robot while performing the Braitenberg. A balance of time and error is possible to achieve by the B+Z algorithms.

To be a fully independent system, the external mobile tracking system needs to be removed. A GPS may be integrated with the mobile robot to give precise positioning information. A mobile robot platform with more memory is also desirable so that the robot can process the information itself and self-calculate the gas source location thus removing the need of a base PC.

## References

- [1] Larcombe, M.H.E., 1984. Robotics in nuclear engineering: Computer assisted teleoperation in hazardous environments with particular reference to radiation fields.
- [2] Kazadi, S., Goodman, R., Tsikata, D., Green, D. and Lin, H., 2000. An autonomous water vapor plume tracking robot using passive resistive polymer sensors. *Autonomous robots*, 9(2), pp.175-188.
- [3] Russell, R.A., Thiel, D., Deveza, R. and Mackay-Sim, A., 1995, May. A robotic system to locate hazardous chemical leaks. In *Robotics and Automation, 1995. Proceedings., 1995 IEEE International Conference on* (Vol. 1, pp. 556-561). IEEE.
- [4] Ishida, H., Nakayama, G., Nakamoto, T. and Moriizumi, T., 2005. Controlling a gas/odor plume-tracking robot based on transient responses of gas sensors. *IEEE Sensors Journal*, 5(3), pp.537-545.
- [5] Marques, L., Almeida, N. and De Almeida, A.T., 2003, October. Olfactory sensory system for odour-plume tracking and localization. In *Sensors, 2003. Proceedings of IEEE* (Vol. 1, pp. 418-423). IEEE.
- [6] Neumann, P.P., Hernandez Bennetts, V., Lilienthal, A.J., Bartholmai, M. and Schiller, J.H., 2013. Gas source localization with a micro-drone using bio-inspired and particle filter-based algorithms. *Advanced Robotics*, 27(9), pp.725-738.
- [7] Lilienthal, A., Ulmer, H., Frohlich, H.A.A.S., Stutzle, A., Werner, F. and Zell, A., 2004, April. Gas source declaration with a mobile robot. In *Robotics and Automation, 2004. Proceedings. ICRA'04. 2004 IEEE International Conference on* (Vol. 2, pp. 1430-1435). IEEE.
- [8] Cabrita, G. and Marques, L., 2013, June. Divergence-based odor source declaration. In *Control Conference (ASCC), 2013 9th Asian* (pp. 1-6). IEEE.
- [9] Rozas, R., Morales, J. and Vega, D., 1991, June. Artificial smell detection for robotic navigation. In *Advanced Robotics, 1991. Robots in Unstructured Environments', 91 ICAR., Fifth International Conference on* (pp. 1730-1733). IEEE.
- [10] Kuwana, Y., Shimoyama, I. and Miura, H., 1995, August. Steering control of a mobile robot using insect antennae. In *Intelligent Robots and Systems 95. Human Robot Interaction and Cooperative Robots', Proceedings. 1995 IEEE/RSJ International Conference on* (Vol. 2, pp. 530-535). IEEE.
- [11] Kuwana, Y., Nagasawa, S., Shimoyama, I. and Kanzaki, R., 1999. Synthesis of the pheromone-oriented behaviour of silkworm moths by a mobile robot with moth antennae as pheromone sensors. *Biosensors and Bioelectronics*, 14(2), pp.195-202.
- [12] Kazadi, S., Goodman, R., Tsikata, D., Green, D. and Lin, H., 2000. An autonomous water vapor plume tracking robot using passive resistive polymer sensors. *Autonomous robots*, 9(2), pp.175-188.
- [13] Braitenberg, V., 1986. *Vehicles: Experiments in synthetic psychology*. MIT press.
- [14] Sandini, G., Lucarini, G. and Varoli, M., 1993, July. Gradient driven self-organizing systems. In *Intelligent Robots and Systems' 93, IROS'93. Proceedings of the 1993 IEEE/RSJ International Conference on* (Vol. 1, pp. 429-432). IEEE.
- [15] Farah, A.M. and Duckett, T., 2002. Reactive localisation of an odour source by a learning mobile robot. In *In Proceedings of the Second Swedish Workshop on Autonomous Robotics*.
- [16] Lilienthal, A. and Duckett, T., 2003. Experimental analysis of smelling Braitenberg vehicles. *environment*, 5(10).
- [17] Marques, L., Nunes, U. and de Almeida, A.T., 2002. Olfaction-based mobile robot navigation. *Thin solid films*, 418(1), pp.51-58.
- [18] Russell, R.A., 2003. Chemical source location and the robomole project. In *Proceedings Australian Conference on Robotics and Automation*.
- [19] Ferri, G., Caselli, E., Mattoli, V., Mondini, A., Mazzolai, B. and Dario, P., 2009. SPIRAL: A novel biologically-inspired algorithm for gas/odor source localization in an indoor environment with no strong airflow. *Robotics and Autonomous Systems*, 57(4), pp.393-402.

- [20] Li, J.G., Meng, Q.H., Wang, Y. and Zeng, M., 2011. Odor source localization using a mobile robot in outdoor airflow environments with a particle filter algorithm. *Autonomous Robots*, 30(3), pp.281-292.
- [21] Lilienthal, A. and Duckett, T., 2003. Approaches to gas source tracing and declaration by pure chemo-tropotaxis. In *Autonome Mobile Systeme 2003* (pp. 161-171). Springer, Berlin, Heidelberg.
- [22] Villarreal, B.L., Olague, G. and Gordillo, J.L., 2016. Synthesis of odor tracking algorithms with genetic programming. *Neurocomputing*, 175, pp.1019-1032.
- [23] Ferri, G., Caselli, E., Mattoli, V., Mondini, A., Mazzolai, B. and Dario, P., 2006, February. A biologically-inspired algorithm implemented on a new highly flexible multi-agent platform for gas source localization. In *Biomedical Robotics and Biomechanics, 2006. BioRob 2006. The First IEEE/RAS-EMBS International Conference on* (pp. 573-578). IEEE.
- [24] Buscemi, L., Prati, M. and Sandini, G., 1994. Cellular robotics: behaviour in polluted environments.
- [25] Grasso, F.W. and Atema, J., 2002. Integration of flow and chemical sensing for guidance of autonomous marine robots in turbulent flows. *Environmental Fluid Mechanics*, 2(1), pp.95-114.
- [26] Cowen, E.A. and Ward, K.B., 2002. Chemical plume tracing. *Environmental Fluid Mechanics*, 2(1), pp.1-7.
- [27] Duckett, T., Axelsson, M. and Saffiotti, A., 2001. Learning to locate an odour source with a mobile robot. In *Robotics and Automation, 2001. Proceedings 2001 ICRA. IEEE International Conference on* (Vol. 4, pp. 4017-4022). IEEE.
- [28] Weissburg, M.J., Dusenbery, D.B., Ishida, H., Janata, J., Keller, T., Roberts, P.J.W. and Webster, D.R., 2002. A multidisciplinary study of spatial and temporal scales containing information in turbulent chemical plume tracking. *Environmental Fluid Mechanics*, 2(1-2), pp.65-94.
- [29] Li, Q., Liu, Z. and Xiao, X., 2015. A gas source localization algorithm based on particle filter in wireless sensor network. *International Journal of Distributed Sensor Networks*, 11(11), p.874532.
- [30] Syed Zakaria, S.M.M., Visvanathan, R., Kamarudin, K., Ali Yeon, A.S., Md Shakaff, A.Y., Zakaria, A. and Kamarudin, L.M., 2015. Development of a Scalable Testbed for Mobile Olfaction Verification. *Sensors*, 15(12), pp.30894-30912.
- [31] Visvanathan, R., Mamduh, S.M., Kamarudin, K., Yeon, A.S.A., Zakaria, A., Shakaff, A.Y.M., Kamarudin, L.M. and Saad, F.S.A., 2015, November. Mobile robot localization system using multiple ceiling mounted cameras. In *SENSORS, 2015 IEEE* (pp. 1-4). IEEE.
- [32] Ishida, H., Wada, Y. and Matsukura, H., 2012. Chemical sensing in robotic applications: A review. *IEEE Sensors Journal*, 12(11), pp.3163-3173.
- [33] Hernandez Bennetts, V., Schaffernicht, E., Pomareda, V., Lilienthal, A.J., Marco, S. and Trincavelli, M., 2014. Combining non selective gas sensors on a mobile robot for identification and mapping of multiple chemical compounds. *Sensors*, 14(9), pp.17331-17352.
- [34] Turduev, M., Cabrita, G., Kirtay, M., Gazi, V. and Marques, L., 2014. Experimental studies on chemical concentration map building by a multi-robot system using bio-inspired algorithms. *Autonomous agents and multi-agent systems*, 28(1), pp.72-100.
- [35] Lochmatter, T., 2010. Bio-inspired and probabilistic algorithms for distributed odor source localization using mobile robots. *EPFL Distributed Intelligent Systems and Algorithms Laboratory, Lausanne*.